

## Nuclear Polarization in Homogeneous InSb by a Direct Current\*

M. WEGER

University of California, San Diego, La Jolla, California

(Received 3 June 1963)

Clark and Feher have shown that an electric field applied to InSb in a constant magnetic field produces nuclear polarization. Two mechanisms are suggested here to account for nuclear polarizations in homogeneous samples. In one mechanism, the kinetic temperatures of "spin up" and "spin down" electron distributions,  $\theta_R^+$  and  $\theta_R^-$ , are assumed to be different. It is shown that a nuclear polarization of order  $N^+/N^- \approx [\tau_N(\theta_R^-)/\tau_N(\theta_R^+)] [\tau_e(\theta_R^+)/\tau_e(\theta_R^-)]$  may be produced in this case.  $\tau_N$  and  $\tau_e$  are the nuclear and electronic longitudinal relaxation times ( $T_1$ 's). In the second mechanism, the momentum distribution is assumed to be displaced by an amount  $\Delta p$  due to the applied electric field. A nuclear polarization of order  $\Delta p^2/2m^*E_F$  may be induced in this case. It is suggested that a sizable fraction of the nuclear polarization observed by Clark and Feher is due to the first of these mechanisms.

### I. INTRODUCTION

IT has been shown by Overhauser<sup>1</sup> that in a system in which electrons interact with nuclei via a scalar interaction  $A(\mathbf{I} \cdot \mathbf{s})$ , a certain type of nonequilibrium stationary electronic distribution results in nuclear polarization exceeding the equilibrium value by a factor of order  $\gamma_e/\gamma_N$ , where  $\gamma_e$ ,  $\gamma_N$  are the electronic and nuclear gyromagnetic ratios. Feher<sup>2</sup> has generalized this and shown that when the distribution can be characterized by spin and kinetic (reservoir) temperatures  $\theta_s$ ,  $\theta_R$ , and  $\theta_s \neq \theta_R$ , then a nuclear polarization of order  $\tanh[\omega_e|1/\theta_R - 1/\theta_s|]$  may be obtained.  $\omega_e$  is the Zeeman energy of the electrons in the external magnetic field. He suggested that a stationary distribution in which  $\theta_R \neq \theta_s$  be established in a semiconductor by applying an electric field that is sufficiently strong to ensure that Ohm's law is broken (i.e., that the electrons are "hot"). Clark and Feher<sup>3</sup> have shown, that an electric direct current of a few milliamperes can, in fact, polarize indium and antimony nuclei in InSb.

It is unlikely that the momentum distribution of hot electrons can be characterized by a unique temperature<sup>4</sup>; furthermore, if the distribution could be characterized by a temperature, and the electron spins were relaxed by interacting with the conduction electrons only,  $\theta_s$  would equal  $\theta_R$  (though both might differ from the lattice temperature  $\theta_l$ ), and no excess nuclear polarization would result [Fig. 1(a)].

The transport phenomena in InSb are not yet fully understood, so at the present stage we try to understand the relevant processes leading to a nuclear polarization by means of certain artificial, vastly oversimplified models. One model describing a system in which a difference between  $\theta_R$  and  $\theta_s$  is established was suggested by Feher.<sup>2</sup> [See Fig. 1(b).] Paramagnetic impurities possessing a very short spin lattice relaxation times are

introduced into the lattice. If these impurities interact with the conduction electrons sufficiently strongly by means of some exchange-type interaction, a difference between  $\theta_R$  and  $\theta_s$  can be established in the stationary state. Another model was suggested by Clark and Feher.<sup>2,3</sup> They show that when some inhomogeneity is introduced into InSb by inhomogeneous concentrations of impurities, or by inhomogeneous electric fields,  $\theta_s$  at a given point in the semiconductor may differ from  $\theta_R$  at that point, and, consequently, a nuclear polarization may be obtained [Fig. 1(c)]. In the present paper, we shall consider idealized models of homogeneous systems, in which no localized paramagnetic impurities are very effective. We shall also assume that the relaxation processes can be described by rate equations. Two types of situations will be considered: (a) The electronic "spin up" and "spin down" distributions will be assumed to be described by temperatures,  $\theta_R^+$ ,  $\theta_R^-$ , which, however, will no longer be assumed equal [Fig. 1(d)]; and (b). The electronic distribution will be assumed to be displaced in momentum space [Fig. 1(e)].

### II. THE ELECTRONIC AND NUCLEAR RATE EQUATIONS

In the present paper we neglect nuclear quadrupole effects. Consequently, we can consider, without loss of generality, systems in which the nuclear spin is  $I = \frac{1}{2}$ . [The population ratios  $N(I_z)/N(I_z - 1)$  depend only on the nuclear Zeeman energy  $\omega_N$  and not on  $I$ . The nuclear polarization depends on  $I$ , of course.] Let  $N^+$ ,  $N^-$  be the fractions of nuclei with  $I_z = +\frac{1}{2}$ ,  $-\frac{1}{2}$ , respectively. The nuclear spin rate equation will then be<sup>5</sup>

$$\frac{dN^-}{dt} = -\frac{dN^+}{dt} = -\frac{2\pi}{\hbar} \sum_{\mathbf{p}} \sum_{\mathbf{p}'} \{N^+ |\langle \mathbf{p}, - | \mathcal{H}_{N_e} | \mathbf{p}', + \rangle|^2 \times f^-(\mathbf{p}) [1 - f^+(\mathbf{p}')] - N^- |\langle \mathbf{p}', + | \mathcal{H}_{N_e} | \mathbf{p}, - \rangle|^2 \times f^+(\mathbf{p}') [1 - f^-(\mathbf{p})] \} \delta(\mathbf{p}^2 - \mathbf{p}'^2 + \omega_e - \omega_N). \quad (1)$$

In this equation,  $\mathcal{H}_{N_e} = A(\mathbf{I} \cdot \mathbf{s})$  is the electron-nuclear

\* Work supported by the National Science Foundation, Washington, D. C.

<sup>1</sup> A. W. Overhauser, Phys. Rev. **92**, 411 (1953).

<sup>2</sup> G. Feher, Phys. Rev. Letters **3**, 135 (1959).

<sup>3</sup> W. G. Clark and G. Feher, Phys. Rev. Letters **10**, 134 (1963).

<sup>4</sup> M. Glicksman and W. A. Hicinbotham, Phys. Rev. **129**, 1572 (1963); R. Stratton, Proc. Roy. Soc. (London) **A242**, 355 (1957); *ibid.* **A246**, 406 (1958).

<sup>5</sup> A. Abragam, *Nuclear Magnetism* (Oxford University Press, New York, 1961).

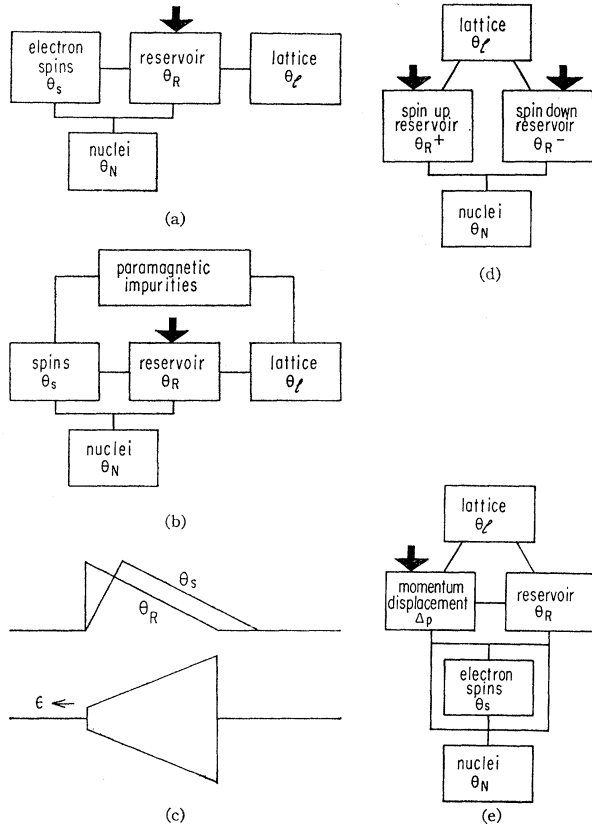

FIG. 1. (a) The "hot electron" scheme proposed by Feher. Nuclear polarization is produced when  $\theta_R \neq \theta_s$ ; (b) the scheme suggested by Feher to provide for a difference between  $\theta_R$  and  $\theta_s$ ; (c) the scheme employed by Clark and Feher to establish a difference between  $\theta_R$  and  $\theta_s$  by the application of an inhomogeneous electric field; (d) different kinetic temperatures of "spin up" and "spin down" distributions can result in a net nuclear polarization. See Sec. III; (e) a displacement of the momentum distribution can result in a net nuclear polarization. See Sec. IV.

hyperfine interaction,  $f^+(\mathbf{p})$ ,  $f^-(\mathbf{p})$  are the distribution function for "spin up" and "spin down" electrons, respectively, and  $\mathbf{p}$  is measured in such units that  $\mathbf{p}^2 = E(\mathbf{p})$  is the electronic kinetic energy.  $\omega_e$  and  $\omega_N$  are the electronic and nuclear Zeeman energies. The +, - signs in the expression for the matrix elements refer to the electron spin.

A similar equation governs the relaxation of *electronic* spins and is

$$\frac{dn^+}{dt} - \frac{dn^-}{dt} = \frac{2\pi}{\hbar} \sum_{\mathbf{p}} \sum_{\mathbf{p}'} \{ |\langle \mathbf{p}, - | \mathcal{H}_{eR} | \mathbf{p}', + \rangle|^2 \times f^-(\mathbf{p}) [1 - f^+(\mathbf{p}')] - |\langle \mathbf{p}', + | \mathcal{H}_{eR} | \mathbf{p}, - \rangle|^2 \times f^+(\mathbf{p}') [1 - f^-(\mathbf{p})] \} \delta(\mathbf{p}^2 - \mathbf{p}'^2 + \omega_e). \quad (2)$$

Here,  $n^\pm = \sum_{\mathbf{p}} f^\pm(\mathbf{p})$  is the density of electrons with spin "up" and "down," respectively.  $\mathcal{H}_{eR}$  is the Hamiltonian describing the interaction between the electronic spins and the reservoir. The electronic direct spin-lattice interaction is not included in this formula.

Feher's expression for the nuclear polarization<sup>2</sup> follows immediately from (1). Let

$$f^\pm(\mathbf{p}) = \{ \exp[(\mathbf{p}^2 - E_F)/\theta_R \mp \omega_e/2\theta_s] + 1 \}^{-1}.$$

This equality may be regarded as a definition of  $\theta_s$ . Note that  $\theta_s$  defined this way satisfies the relationship  $\lim_{\mathbf{p} \rightarrow \infty} f^+(\mathbf{p})/f^-(\mathbf{p}) = \exp(\omega_e/\theta_s)$ , which may be regarded as an alternative definition of  $\theta_s$ .<sup>6</sup> Substitute in (1);

$$\begin{aligned} \frac{dN^-}{dt} - \frac{dN^+}{dt} &= \frac{2\pi}{\hbar} \sum_{\mathbf{p}} \sum_{\mathbf{p}'} |\langle \mathbf{p}, - | \mathcal{H}_{N\epsilon} | \mathbf{p}', + \rangle|^2 \\ &\times \{ \exp[(\mathbf{p}^2 - E_F)/\theta_R + \omega_e/2\theta_s] + 1 \}^{-1} \\ &\times \{ \exp[(\mathbf{p}'^2 - E_F)/\theta_R - \omega_e/2\theta_s] + 1 \}^{-1} \\ &\times \delta(\mathbf{p}^2 - \mathbf{p}'^2 + \omega_e - \omega_N) \\ &\times \{ N^+ \exp[(\mathbf{p}'^2 - E_F)/\theta_R - \omega_e/2\theta_s] \\ &\quad - N^- \exp[(\mathbf{p}^2 - E_F)/\theta_R + \omega_e/2\theta_s] \}. \end{aligned}$$

Making use of the relationship  $\mathbf{p}^2 = \mathbf{p}'^2 - \omega_e + \omega_N$  ensured by the  $\delta$  function, the last term can be written in the form

$$\exp[(\mathbf{p}'^2 - E_F)/\theta_R - \omega_e/2\theta_s] \times \{ N^+ - N^- \exp[-\omega_e - \omega_N]/\theta_R + \omega_e/\theta_s \}.$$

Thus, when  $(N^+/N^-) \exp(-\omega_N/\theta_R) = \exp[\omega_e(1/\theta_s - 1/\theta_R)]$  then  $dN^+/dt = 0$ . This proves Feher's relationship for the case of Fermi-Dirac statistics.

The following theorem follows directly from (1), (2):

*Theorem I:* If  $\omega_N$  is neglected in the  $\delta$  function in (1), and if  $|\langle \mathbf{p}, - | \mathcal{H}_{N\epsilon} | \mathbf{p}', + \rangle|^2 = C |\langle \mathbf{p}, - | \mathcal{H}_{eR} | \mathbf{p}', + \rangle|^2$ , where  $C$  is independent of  $\mathbf{p}$ ,  $\mathbf{p}'$ , and if  $dN^+/dt = dn^+/dt = 0$ , then  $N^+ = N^-$ .

The proof of the theorem is trivial. Its significance is that, when the matrix elements for nuclear and electronic relaxation are proportional, no nuclear polarization (in excess of the Boltzmann value) is present in a homogeneous system in the stationary state. This lack of polarization is independent of the form of  $f^+(\mathbf{p})$ ,  $f^-(\mathbf{p})$ , and, thus, will hold for *any* electronic distribution. The matrix element for hyperfine interaction is independent of  $\mathbf{p}$ ,  $\mathbf{p}'$ ; consequently, if the matrix element of the interaction responsible for electron spin relaxation is independent of  $\mathbf{p}$ ,  $\mathbf{p}'$ , then no nuclear polarization is possible with the schemes discussed here.

### III. DIFFERENT KINETIC TEMPERATURES OF "SPIN UP" AND "SPIN DOWN" ELECTRONS

The electrical conductivity of InSb at low temperatures is due to electrons (or holes) in the impurity band. If the semiconductor is not compensated, the concentration of electrons equals the concentration of charged impurities; if it is compensated, the density

<sup>6</sup> The definition of  $\theta_s$  is not trivial. In this connection, see C. P. Slichter, Phys. Rev. **99**, 1822 (1955).

of charged impurities may exceed that of electrons. Consequently, the electron-impurity Coulomb interaction is not weak compared with the electron-electron interaction, and, therefore, when the electrons are "hot," the electron momentum distribution is most likely not even a displaced Fermi distribution.<sup>4</sup> Let us consider a hypothetical situation in which the spin up and spin down systems can be characterized by kinetic temperatures  $\theta_{R^+}$  and  $\theta_{R^-}$ , but  $\theta_{R^+} \neq \theta_{R^-}$ . In this case, the rate equations simplify to

$$\begin{aligned} \frac{dN^-}{dt} = -\frac{dN^+}{dt} = & \int \rho(E)dE \int \rho(E')dE' P_N(E, E') \\ & \times \{N^+ f^-(E, \theta_{R^-}) [1 - f^+(E', \theta_{R^+})] - N^- f^+(E', \theta_{R^+}) \\ & \times [1 - f^-(E, \theta_{R^-})]\} \delta(E - E' + \omega_e - \omega_N), \quad (3) \end{aligned}$$

$$\begin{aligned} \frac{dn^+}{dt} = -\frac{dn^-}{dt} = & \int \rho(E)dE \int \rho(E')dE' P_\epsilon(E, E') \\ & \times \{f^-(E, \theta_{R^-}) [1 - f^+(E', \theta_{R^+})] - f^+(E', \theta_{R^+}) \\ & \times [1 - f^-(E, \theta_{R^-})]\} \delta(E - E' + \omega_e), \quad (4) \end{aligned}$$

where

$$\begin{aligned} (4\pi)^2 P_N(E, E') = & \frac{2\pi}{\hbar} \int_{p^2=E} d\Omega_p \int_{p'^2=E'} d\Omega_{p'} \\ & \times |\langle p, - | 3C_{N\epsilon} | p', + \rangle|^2, \quad \text{etc.}, \end{aligned}$$

and  $\rho(E)$  is the density of states.

Under conditions in which the electrons obey Boltzmann statistics, the rate equations can be further simplified. We define

$$\begin{aligned} n^\mp w_{N^\pm}(\theta) = & \int \rho(E)dE \int \rho(E')dE' \\ & \times P_N(E, E') f^\mp \left( \frac{E}{E'}, \theta \right) \delta(E - E' + \omega_e), \quad (5) \end{aligned}$$

$$\begin{aligned} n^\pm w_{\epsilon^\pm}(\theta) = & \int \rho(E)dE \int \rho(E')dE' \\ & \times P_\epsilon(E, E') f^\pm \left( \frac{E'}{E}, \theta \right) \delta(E - E' + \omega_e). \end{aligned}$$

The +, - signs in  $w_{N^\pm}(\theta)$  and  $w_{\epsilon^\pm}(\theta)$  refer to the nuclear and electron spins, respectively. The rate equations reduce to

$$\begin{aligned} dN^-/dt = -dN^+/dt = & w_{N^+}(\theta_{R^-})N^+n^- - w_{N^-}(\theta_{R^+})N^-n^+, \\ dn^+/dt = -dn^-/dt = & w_{\epsilon^-}(\theta_{R^-})n^- - w_{\epsilon^+}(\theta_{R^+})n^+ \end{aligned}$$

(neglecting  $\omega_N$  in the  $\delta$  function). The relationship between  $w_{N^+}(\theta)$  and  $w_{N^-}(\theta)$  can be derived from the principle of detailed balance. At equilibrium,

$$\begin{aligned} w_{\epsilon^-}(\theta_R)/w_{\epsilon^+}(\theta_R) = & n_0^+/n_0^- = \exp(\omega_e/\theta_R); \\ 1/\tau_\epsilon(\theta_R) = & w_{\epsilon^-}(\theta_R) + w_{\epsilon^+}(\theta_R), \end{aligned}$$

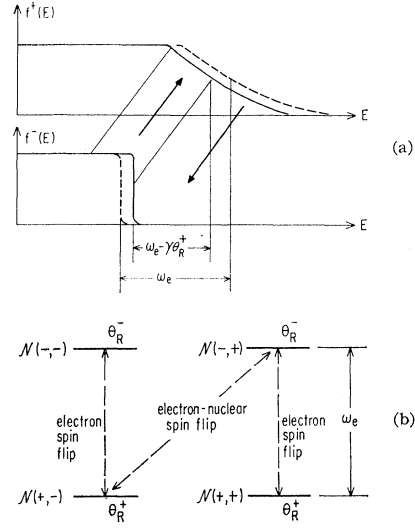

Fig. 2. (a) When  $\theta_{R^+} \neq \theta_{R^-}$ , the "spin up" and "spin down" kinetic contributions will adjust themselves in the stationary state so that the number of electronic spin flips "up" equals the number of flips "down." When the transition matrix elements for electronic and for mutual electron-nuclear spin flips are not proportional, this situation may result in a net nuclear polarization. (b) Illustration of the process of establishing electronic and nuclear spin polarizations by different spin up and spin down kinetic temperatures.

where  $\tau_\epsilon(\theta_R)$  is the electronic longitudinal relaxation time.

$$\begin{aligned} w_{N^+}(\theta_R)/w_{N^-}(\theta_R) = & n_0^+N_0^-/n_0^-N_0^+ \approx \exp(\omega_e/\theta_R), \\ & (\text{since } \omega_N \ll \omega_e) \end{aligned}$$

$$\begin{aligned} 1/\tau_N(\theta_R) = & w_{N^+}(\theta_R)n_0^- + w_{N^-}(\theta_R)n_0^+ \\ = & 2w_{N^+}(\theta_R)n_0^- = 2w_{N^-}(\theta_R)n_0^+. \end{aligned}$$

Making use of these relationships, the rate equations can be written in the form

$$\begin{aligned} \frac{dn^+}{dt} = -\frac{dn^-}{dt} = & \left\{ \tau_\epsilon(\theta_{R^-}) \left[ 1 + \exp\left(-\frac{\omega_e}{\theta_{R^-}}\right) \right] \right\}^{-1} n^- \\ & - \left\{ \tau_\epsilon(\theta_{R^+}) \left[ 1 + \exp\left(\frac{\omega_e}{\theta_{R^+}}\right) \right] \right\}^{-1} n^+, \quad (6) \end{aligned}$$

$$\begin{aligned} \frac{dN^-}{dt} = -\frac{dN^+}{dt} = & -[2\tau_N(\theta_{R^-})n_0^-(\theta_{R^+})]^{-1}N^+n^- \\ & - [2\tau_N(\theta_{R^+})n_0^+(\theta_{R^-})]^{-1}N^-n^+, \end{aligned}$$

and at equilibrium

$$\begin{aligned} \frac{n^+}{n^-} = & \frac{\tau_\epsilon(\theta_{R^+})[1 + \exp(\omega_e/\theta_{R^+})]}{\tau_\epsilon(\theta_{R^-})[1 + \exp(-\omega_e/\theta_{R^-})]} = \frac{\tau_\epsilon(\theta_{R^+})n_0^+(\theta_{R^-})}{\tau_\epsilon(\theta_{R^-})n_0^-(\theta_{R^+})}, \\ \frac{N^+}{N^-} = & \frac{n^+ \tau_N(\theta_{R^-})n_0^-(\theta_{R^+})}{n^- \tau_N(\theta_{R^+})n_0^+(\theta_{R^-})} = \frac{\tau_\epsilon(\theta_{R^+})\tau_N(\theta_{R^-})}{\tau_\epsilon(\theta_{R^-})\tau_N(\theta_{R^+})}. \end{aligned}$$

This way the nuclear polarization is related to the temperature dependence of the electronic and nuclear

relaxation times. When  $\tau_\epsilon$  and  $\tau_N$  have the same temperature dependence, there will be no nuclear polarization (in excess of the Boltzmann value). This is a slight generalization of Theorem I. For the hyperfine interaction postulated for this model,  $\tau_N(\theta)$  is inversely proportional to  $\theta$ . Consequently, if  $\tau_\epsilon(\theta)$  is proportional to  $\theta^{\alpha-1}$ , then  $N^+/N^- = (\theta_{R^+}/\theta_{R^-})^\alpha$ ; thus if  $\alpha$  is of order unity, nuclear polarizations of order unity can be expected, if a sizable temperature difference can be established between the spin up and spin down electronic distributions.

This is the main result of the present paper, therefore it may be advantageous to dwell on it further. The treatment of the rate equations here follows the lines of Overhauser's paper.<sup>1</sup> Following Overhauser's paper, his results have often been described in a slightly different way; see Fig. 2(a) and Ref. 5 p. 345. Let  $\mathfrak{X}(\pm, \pm)$  be the probability to find an electron-nucleus pair with  $s_z = \pm \frac{1}{2}$ ,  $I_z = \pm \frac{1}{2}$ . (The first sign refers to the electron; the second to the nuclear spin.) Then, by (6),

$$\frac{\mathfrak{X}(+, -)}{\mathfrak{X}(-, -)} = \frac{\mathfrak{X}(+, +)}{\mathfrak{X}(-, +)}$$

$$= \exp\left(\frac{\omega_e}{\theta_{R^-}} \frac{\tau_\epsilon(\theta_{R^+})}{\tau_\epsilon(\theta_{R^-})} \frac{1 + \exp(\omega_e/\theta_{R^+})}{1 + \exp(\omega_e/\theta_{R^-})}\right) \quad (6a)$$

and

$$\frac{\mathfrak{X}(-, +)}{\mathfrak{X}(+, -)} = \exp\left(-\frac{\omega_e}{\theta_{R^-}} \frac{\tau_N(\theta_{R^-})}{\tau_N(\theta_{R^+})} \frac{1 + \exp(\omega_e/\theta_{R^-})}{1 + \exp(\omega_e/\theta_{R^+})}\right). \quad (6b)$$

Consequently,

$$\frac{N^+}{N^-} = \frac{\mathfrak{X}(+, +) + \mathfrak{X}(-, +)}{\mathfrak{X}(+, -) + \mathfrak{X}(-, -)}$$

$$= \frac{\mathfrak{X}(-, +) \mathfrak{X}(+, -)}{\mathfrak{X}(+, -) \mathfrak{X}(-, -)} = \frac{\tau_\epsilon(\theta_{R^+}) \tau_N(\theta_{R^-})}{\tau_\epsilon(\theta_{R^-}) \tau_N(\theta_{R^+})}.$$

Note that when  $\omega_e \ll \theta_{R^-}$ ,  $\theta_{R^+}$ , then (6a) reduces to

$$\frac{\mathfrak{X}(+, -)}{\mathfrak{X}(-, -)} = \frac{\mathfrak{X}(+, +)}{\mathfrak{X}(-, +)} = \frac{\tau_\epsilon(\theta_{R^+})}{\tau_\epsilon(\theta_{R^-})},$$

thus, if we can maintain a difference between  $\theta_{R^+}$  and  $\theta_{R^-}$ , we can establish an electron spin polarization (i.e., a very low spin temperature), and in principle at least, invert electron spin polarizations.

When  $\theta_{R^-} \ll E_F$ , and we have degenerate Fermi statistics, the preceding approximation does not apply. However, we can estimate the nuclear polarization in this case, assuming for simplicity that  $\theta_{R^-} = 0$ ,  $\omega_e \ll E_F$ . (See Fig. 2.) Let us define a dimensionless parameter  $\gamma$  by  $E_F^- + \omega_e = E_F^+ + \gamma\theta_{R^+}$ . [ $E_F^+$ ,  $E_F^-$  are defined by  $f(E_F) = \frac{1}{2}$ .] The rate equation for the electronic spin transition is now

$$\frac{dn^+}{dt} - \frac{dn^-}{dt} = \int_0^{E_F^-} dE$$

$$\times \rho(E) \rho(E + \omega_e) P_\epsilon(E, E + \omega_e) [1 - f^+(E + \omega_e)]$$

$$- \int_{E_F^-}^{\infty} dE \rho(E) \rho(E + \omega_e) P_\epsilon(E, E + \omega_e) f^+(E + \omega_e)$$

$$\approx \rho(E_F^-) \rho(E_F^+) [\theta_{R^+} (1 + \gamma) P_\epsilon(E_F^+ - \frac{1}{2}\theta_{R^+})$$

$$- \theta_{R^+} (1 - \gamma) P_\epsilon(E_F^+ + \frac{1}{2}\theta_{R^+})]. \quad (7)$$

In addition there is a term involving  $d\rho(E)/dE$ , but this term will not create a nuclear polarization, by Theorem I. In the stationary state,  $dn^+/dt = 0$  and, therefore,

$$\gamma \approx [1/P_\epsilon(E_F^+)] [dP_\epsilon(E_F^+)/dE] \theta_{R^+}.$$

Let us define a dimensionless quantity  $\alpha$  by

$$\alpha = \frac{1}{E_F^+} \frac{dP_\epsilon(E_F^+)}{P_\epsilon(E_F^+) dE}.$$

When the transition matrix element depends on  $E$ ,  $\alpha$  will be different from zero, and if the dependence is not very weak,  $\alpha$  will be of order unity. Thus,  $\gamma \approx \alpha \theta_{R^+}/E_F$ , and the nuclear polarization will be of the same order.

#### IV. DISPLACEMENT OF THE MOMENTUM DISTRIBUTION

When the electron-electron interactions are strong compared with the electron lattice interactions,  $\theta_{R^+} \approx \theta_{R^-}$ , and the mechanism discussed in Sec. III cannot yield appreciable nuclear polarization. However, under the influence of a strong electric field, the electron momentum distribution as a whole may shift, and if this shift is appreciable, it can induce appreciable nuclear polarization [Fig. 1(e)]. The displacement  $\Delta p$  of the distribution is given by  $\Delta p = m^* \Delta v_{\text{drift}} = m^* \mu \epsilon$ , where  $m^*$  is the effective mass (assumed isotropic),  $\mu$  is the mobility, and  $\epsilon$  is the applied electric field. If the displacement is small, i.e.,  $\Delta p^2/2m^* \ll \theta_{R^-}$ , we can expand the distribution function in powers of  $\Delta p$  and evaluate the rate equations. Let us express  $\Delta p$  in units of (energy)<sup>1/2</sup>, i.e., in units of  $p/(2m^*)^{1/2}$ .

##### (a) Maxwell-Boltzmann Statistics

It is not difficult to show that for a Boltzmann distribution, and for momentum-independent matrix elements, a momentum shift  $\Delta p$  will result in an extra *electronic* spin polarization of value

$$(n^+/n^-) \exp(-\omega_e/\theta_{R^-}) \approx 1 - \Delta p^2 \times \frac{2}{3} (\omega_e/\theta_{R^-}), \quad (8)$$

this approximation being good to order  $\Delta p^2$ . Similarly, for the nuclear polarization, the same expansion yields

$$(N^+/N^-) \exp(-\omega_N/\theta_{R^-}) \exp[\omega_e(1/\theta_{R^-} - 1/\theta_{R^+})]$$

$$\approx 1 - \Delta p^2 \times \frac{2}{3} (\omega_e/\theta_{R^-}). \quad (9)$$

FIG. 3. Displaced momentum distribution. The change in kinetic energy involved in a spin flip is  $\omega_e$ . When the distribution is displaced, this energy change results in different momentum changes for electrons flipping "down" and "up." If the transition matrix element depends on the momentum change, the transition matrix elements will no longer be equal and a net nuclear polarization may be established.

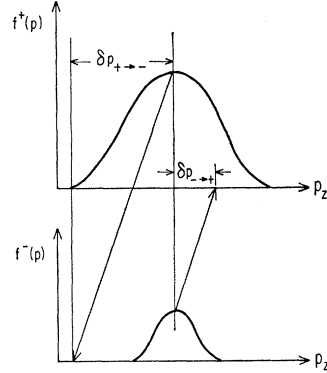

When we make use of (8) to evaluate  $\theta_s$  by the relationship  $n^+/n^- = \exp(-\omega_e/\theta_s)$ , and substitute this value in (9), we get  $N^+/N^- = \exp(-\omega_N/\theta_R)$ , which indicates that no nuclear polarization in excess of the Boltzmann value is established. This is, of course, an immediate corollary of Theorem I. We shall prove even a slightly more general result; namely, for Boltzmann statistics, there is no increase in nuclear polarization to order  $\Delta\mathbf{p}^2/\theta_R$  even if the matrix element for an electronic spin flip depends on  $|\mathbf{p}-\mathbf{p}'|$ . The proof is as follows:

Let  $f^\pm(\mathbf{p}) = \theta_R^{-3/2} A^\pm(\theta_s) \exp(-\mathbf{p}^2/\theta_R)$ . Then,

$$f^\pm(\mathbf{p}-\Delta\mathbf{p}) = f^\pm(\mathbf{p}) + 2(\mathbf{p} \cdot \Delta\mathbf{p}/\theta_R) f^\pm(\mathbf{p}) + 2[2(\mathbf{p} \cdot \Delta\mathbf{p}/\theta_R)^2 - \Delta\mathbf{p}^2/\theta_R^2] f^\pm(\mathbf{p}) + \dots \quad (10)$$

The term in the rate equations which is proportional to  $\Delta\mathbf{p}$  will vanish, due to the symmetry of the system. (Changing the direction of the applied electric field cannot change the nuclear polarization in the present situation). Also, when the angular integration is performed,  $(\mathbf{p} \cdot \Delta\mathbf{p})^2$  is equivalent to  $\frac{1}{3}\mathbf{p}^2\Delta\mathbf{p}^2$ . Thus, (10) is equivalent to

$$f^\pm(\mathbf{p}-\Delta\mathbf{p}) = (1 - 2\Delta\mathbf{p}^2/\theta_R + \frac{4}{3}\mathbf{p}^2\Delta\mathbf{p}^2/\theta_R^2) f^\pm(\mathbf{p}).$$

We can also expand  $f^\pm(\mathbf{p})$  as a power series in  $\theta_R$ ,

$$f^\pm(\mathbf{p}, \theta_R + \Delta\theta_R) = [1 + (\mathbf{p}^2/\theta_R^2 - 3/2\theta_R)\Delta\theta_R] f^\pm(\mathbf{p}, \theta_R).$$

Thus, when

$$\frac{4\Delta\mathbf{p}^2}{3\theta_R^2} \left/ \left( 1 - \frac{2\Delta\mathbf{p}^2}{\theta_R} \right) \right. = \frac{\Delta\theta_R}{\theta_R^2} \left/ \left( 1 - \frac{2\Delta\theta_R}{3\theta_R^2} \right) \right.,$$

then the two distributions are proportional. Therefore, to order  $\Delta\mathbf{p}^2$ , the displacement  $\Delta\mathbf{p}$  is proportional to an increase in the kinetic temperature of  $\Delta\theta_R = \frac{3}{4}\Delta\mathbf{p}^2$ . A change in  $\theta_R$  per se cannot produce a nuclear polarization (in excess of the Boltzmann factor), and our theorem is proved.

Consequently, for a slightly shifted Boltzmann distribution, the nuclear polarization can be at most of order  $(\Delta\mathbf{p}^2/\theta_R)^2$ .

When  $\Delta\mathbf{p}^2$  is no longer small compared with  $\theta_R$ , large net polarizations may be induced. To illustrate this point, we shall estimate the nuclear polarization for an

artificial model in which the electronic spin-flip matrix element is proportional to  $1/(\mathbf{p}-\mathbf{p}')^2$ , and  $\Delta\mathbf{p}^2 \gg \omega_e$ . Let us consider for simplicity a one-dimensional model, since this does not alter the basic physical features. The rate equation (2) reduces in this case to

$$\frac{dn^+}{dt} = -\frac{dn^-}{dt} = \frac{2\pi}{\hbar} \sum_{\mathbf{p}} \sum_{\mathbf{p}'} |\langle \mathbf{p}, - | \mathcal{H}_{eR} | \mathbf{p}', + \rangle|^2 \times [f^-(\mathbf{p}-\Delta\mathbf{p}) - f^+(\mathbf{p}'-\Delta\mathbf{p})] \delta(\mathbf{p}^2 - \mathbf{p}'^2 + \omega_e). \quad (11)$$

Expanding the momentum change  $\delta\mathbf{p} = |\mathbf{p}' - \mathbf{p}|$  in powers of  $\omega_e/\Delta\mathbf{p}^2$ , we get  $1/\delta\mathbf{p}^4 \approx (\Delta\mathbf{p}/\omega_e)^4 (1 \pm \omega_e/\Delta\mathbf{p}^2)$ , when  $\mathbf{p}\mathbf{p}' > 0$ . (The transitions for which  $\mathbf{p}\mathbf{p}' < 0$  can be neglected in this approximation.) The upper and lower signs apply to the transitions  $+\rightarrow-$  and  $-\rightarrow+$  respectively. We see that the ratio of the transition matrix elements squared is approximately  $1 + 2\omega_e/\Delta\mathbf{p}^2$ , and since by Theorem I no net polarization is expected when the ratio is unity, we may expect to obtain in this case nuclear polarizations of order  $\omega_e/\Delta\mathbf{p}^2$ . Thus, when  $\omega_e \approx \Delta\mathbf{p}^2$ , we may expect to get a nuclear polarization of order unity.

#### (b) Degenerate Fermi-Dirac Statistics

The rate equation (2) for the electronic spin transitions is, for a distribution displaced by an amount  $\Delta\mathbf{p}$ ,

$$\begin{aligned} \frac{dn^+}{dt} &= -\frac{dn^-}{dt} = \frac{2\pi}{\hbar} \sum_{\mathbf{p}} \sum_{\mathbf{p}'} |\langle \mathbf{p}', + | \mathcal{H}_{eR} | \mathbf{p}, - \rangle|^2 \\ &\times \{ f^-(\mathbf{p}-\Delta\mathbf{p}) [1 - f^+(\mathbf{p}'-\Delta\mathbf{p})] \\ &\quad - f^+(\mathbf{p}-\Delta\mathbf{p}) [1 - f^-(\mathbf{p}'-\Delta\mathbf{p})] \} \delta(\mathbf{p}^2 - \mathbf{p}'^2 + \omega_e) \\ &= \frac{2\pi}{\hbar} \sum_{\mathbf{p}} \sum_{\mathbf{p}'} |\langle \mathbf{p}', + | \mathcal{H}_{eR} | \mathbf{p}, - \rangle|^2 \\ &\times \frac{\exp[g(\Delta\mathbf{p})] - \exp[h(\Delta\mathbf{p})]}{\{ \exp[g(\Delta\mathbf{p})] + 1 \} \{ \exp[h(\Delta\mathbf{p})] + 1 \}} \\ &\quad \times \delta(\mathbf{p}^2 - \mathbf{p}'^2 + \omega_e), \quad (12) \end{aligned}$$

where

$$g(\Delta\mathbf{p}) = [(\mathbf{p}-\Delta\mathbf{p})^2 + \frac{1}{2}\omega_e - E_F]/\theta_R,$$

$$h(\Delta\mathbf{p}) = [(\mathbf{p}'-\Delta\mathbf{p})^2 - \frac{1}{2}\omega_e - E_F]/\theta_R.$$

When the displacement of the Fermi surface is small, we can expand  $dn^+/dt$  in powers of  $\Delta\mathbf{p}$ .<sup>7</sup> The term linear in  $\Delta\mathbf{p}$  will vanish due to the symmetry of the problem while, to order  $\Delta\mathbf{p}^2$ ,

$$\begin{aligned} &\frac{\exp[g(\Delta\mathbf{p})] - \exp[h(\Delta\mathbf{p})]}{\{ \exp[g(\Delta\mathbf{p})] + 1 \} \{ \exp[h(\Delta\mathbf{p})] + 1 \}} \\ &= -\frac{\Delta\mathbf{p}^2}{2} \frac{\mathbf{p}^2 - \mathbf{p}'^2}{\theta_R^2} \frac{\exp[g(0)] \{ 1 - \exp[g(0)] \}}{\{ 1 + \exp[g(0)] \}^3} \\ &= -\frac{\Delta\mathbf{p}^2 \omega_e}{2\theta_R \theta_R} f^-(\mathbf{p}) [1 - f^-(\mathbf{p})] [2f^-(\mathbf{p}) - 1]. \quad (13) \end{aligned}$$

<sup>7</sup> The author is indebted to Dr. R. Griffiths for this expansion.

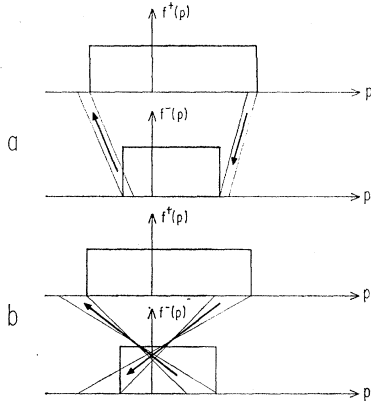

FIG. 4. Allowed transitions for a shifted Fermi distribution. The transitions of type (b) involve a large momentum change, and if the transition matrix elements are small for large momentum changes, these transitions are not very important unless the Zeeman energy is very small. The transitions of type (a) may produce a nuclear polarization, if the transition matrix elements are energy-dependent.

For an arbitrary function  $F(E)$  that is smooth in the vicinity of  $E=E_F$ , the relationship

$$\int F(E)f(E)[1-f(E)][2f(E)-1]dE = -\theta_R \left( \frac{dF(E)}{dE} \right)_{E_F} \quad (14)$$

applies to order  $\theta_R/E_F$ . Let us define a dimensionless parameter  $\alpha$  by

$$\frac{d}{dE} \left( \int d\Omega \int d\Omega' |\langle \mathbf{p}', + | \mathcal{H}_{eR} | \mathbf{p}, - \rangle|^2 \right) = \frac{\alpha}{E_F} \left( \int d\Omega \int d\Omega' |\langle \mathbf{p}', + | \mathcal{H}_{eR} | \mathbf{p}, - \rangle|^2 \right)_{E_F} \quad (15)$$

Then, the electronic spin polarization will change by a factor of

$$1 - \frac{1}{2} \frac{\Delta \mathbf{p}^2 \omega_e \theta_R}{\theta_R \theta_R E_F} \alpha \quad (16)$$

due to the displacement of the Fermi surface, and we may expect to get nuclear polarizations of order  $\alpha(\Delta \mathbf{p}^2/\theta_R)(\omega_e/E_F)$ . This expansion is valid only when  $(\Delta \mathbf{p}^2 \omega_e)^{1/2} \ll \theta_R \ll E_F$ .

When  $\theta_R^2 < \Delta \mathbf{p}^2 \omega_e$ , this approximation does not apply. However, to understand the physics of this particular case, we can consider a particularly simple situation, namely, a one-dimensional model in which  $\theta_R=0$  (Fig. 4). In this model, the allowed transitions are of two types: (a)  $p p' > 0$  (these transitions are due to the fact that when the distribution is displaced, the difference between the momenta of spin up and spin down electrons at the Fermi surface,  $p_F^+ - p_F^-$ , will no longer correspond to an energy difference  $\omega_e$ ); and (b)  $p p' < 0$ , (the displacement of the distribution creates

holes into which the electrons can fall). Let us define parameters  $\beta, \gamma$  by

$$\beta = (p_F^+ - p_F^-)_{\Delta p=0} \approx \omega_e/2(E_F)^{1/2};$$

$$p_F^\pm(\Delta p) = [p_F^\pm(0) + \Delta p](1 \mp \gamma).$$

Then, the rate equation for the electron spins is

$$\frac{dn^+}{dt} = \left\{ \beta \frac{\Delta p}{p_F} \left[ P(\Delta p) + \frac{dP(\Delta p)}{d\Delta p} \right] + 2\Delta p \left[ P(2p_F) + \frac{dP(2p_F)}{d\Delta p} \right] \right\} (1-2\gamma) - \left\{ \beta \frac{\Delta p}{p_F} \left[ P(\Delta p) - \frac{dP(\Delta p)}{d\Delta p} \right] + 2\Delta p \left[ P(2p_F) + \frac{dP(2p_F)}{d\Delta p} \right] \right\} (1+2\gamma), \quad (17)$$

where  $P(\Delta p) = 2\pi/\hbar |\langle p, - | \mathcal{H}_{eR} | p', + \rangle|^2$ . In the stationary state,  $dn^+/dt=0$ , so

$$2\gamma = \left[ \frac{1}{P(\Delta p)} \frac{dP(\Delta p)}{d\Delta p} \Delta p + 1 + 2 \frac{p_F}{\beta} \frac{P(2p_F)}{P(\Delta p)} + 2 \frac{1}{P(\Delta p)} \frac{dP(2p_F)}{d\Delta p} \frac{p_F}{\beta} \Delta p \right]. \quad (18)$$

The last term in the denominator is very small.

When  $P(p)$  decreases with increasing  $p$  sufficiently strongly (roughly, faster than  $1/p$ ), then, when  $\beta$  is not too small, the second term in the denominator is small too. Under these circumstances we may expect to obtain a nuclear polarization of order  $\Delta p/p_F$ . The condition for the validity of this approximation is  $\theta_R < \Delta p^2 < \omega_e^2/E_F$ . When  $\omega_e$  is small, we can still use Eq. (18) as long as  $\Delta p^2 \ll E_F$ .

## V. DISCUSSION

In the previous sections it was shown that appreciable nuclear polarizations may be created if the "kinetic temperatures" of the spin up and spin down distributions,  $\theta_R^+$  and  $\theta_R^-$ , are different, or if the momentum distribution is shifted appreciably. Let us now investigate whether situations reminiscent of these idealized ones may actually exist in the InSb samples investigated by Clark and Feher.<sup>3</sup> Let us first list a number of approximations made in these idealized models.

(i) The interaction of the nuclear spins with anything except the conduction electrons has been neglected. In reality, the nuclei probably relax mostly via paramagnetic impurities in the sample.<sup>3</sup> Such relaxation may short-circuit the polarizing effect and result in actual polarizations several orders of magnitude smaller than the estimated ones. Phenomenologically, the short

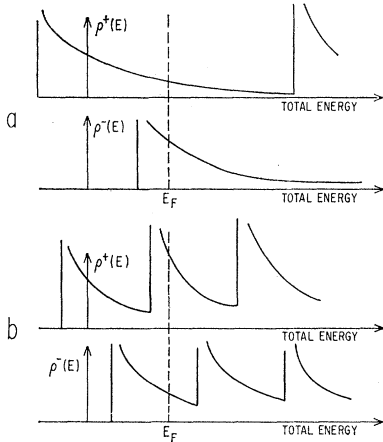

FIG. 5. de-Haas-van-Alphen oscillations of the nuclear polarization expected for the model of Sec. III. When the magnetic field is large, (a), only the lowest Landau level is occupied significantly, and the velocity of "spin up" electrons exceeds that of "spin down" electrons. When an electric field is applied, "spin up" electrons will heat up slower than "spin down" ones, and, therefore,  $\theta_R^+ < \theta_R^-$ . When the magnetic field is somewhat weaker, (b), "spin up" electrons occupy the second Landau level, and as a result the situation may be reversed, and  $\theta_R^+ > \theta_R^-$ , and the nuclear polarization will change sign. In this graph, the density of states is plotted as function of the energy. The average velocity in the direction of the magnetic field is approximately inversely proportional to it.

circuiting of the conduction electron-nuclear interaction manifests itself in  $\tau_N$  being almost independent of  $\theta_R$ . If  $\tau_N$  were due to interaction with the conduction electrons, we would expect  $\tau_N \theta_R$  to be approximately constant, by the Korringa relationship.<sup>8</sup> We can estimate  $\tau_N$  due to the interaction with the conduction electrons by making use of the value of  $|\Psi(0)|^2$  estimated by Gueron.<sup>9</sup> At  $\theta_R = 4^\circ\text{K}$ , for the samples used,  $\tau_N$  due to this interaction may be of order 1000 h for Sb<sup>123</sup>, while the observed  $\tau_N$  is of order 40 h.<sup>3</sup> Thus, the observed nuclear polarization may be expected to be 1 to 2 orders less than the estimated ones.

(ii) The electronic wave functions were assumed to be Bloch waves. Such an assumption is reasonable when  $\theta_R > \omega_c$ , where  $\omega_c = e\hbar H/m^*c$  is the cyclotron frequency. Under the conditions of the experiment,  $\omega_c$  was of order  $k \times 100^\circ\text{K}$ , which is large compared with  $\theta_R$  and, therefore, this assumption is not justified. Most of the estimates presented here are, however, independent of the assumption  $\omega_c < \theta_R$ . When  $\omega_c > \theta_R$ , we must use the eigenfunctions of an electron in a magnetic field, which are characterized by the quantum numbers  $n$ ,  $p_x$ , and  $\nu$ , where the kinetic energy is  $E = (n + \frac{1}{2})\omega_c + p_x^2/2m^*$ , and  $\nu$  is a quantum number distinguishing between degenerate states. Most of the rate equations will still be valid when these quantum numbers replace  $p_x$ ,  $p_y$ , and  $p_z$ . The situation is particularly simple when  $\omega_c \gg \theta_R$ . In that case, only the lowest Landau level contributes significantly to the relaxation. (See Fig. 5.) Of course,

we must use, in the rate equations, the density of states  $\rho(E)$  appropriate for this situation. When the electric and magnetic fields are perpendicular, we must also consider the Ettinghausen effect.<sup>3,10</sup>

(iii) Effects due to electron-electron correlations,<sup>4</sup> and to electron-impurity correlations (such as "freeze-out"<sup>11</sup>) have been neglected.

Electron-electron scattering tends to reduce the difference between  $\theta_R^+$  and  $\theta_R^-$ , thus reducing the nuclear polarization. This factor is very important and must be taken into account in any quantitative estimate of the nuclear polarization. When electron-electron energy exchange is considered, it is very important to take into account the large magnetic field,  $\omega_c \approx E_F < \omega_c$ , which makes it difficult for spin-up and spin-down electrons to exchange energy while the total energy and momentum are conserved.

In the experiments carried out so far, the displacement of the Fermi sphere was probably small. The displacement when the electric and magnetic fields are parallel is given by  $\Delta p = m^* \mu \epsilon$ ; in the samples investigated so far,<sup>3,12</sup>  $m^* \approx 0.014m_0$ ,  $\mu \approx 3 \times 10^5 \text{ cm}^2/\text{V}$  per sec,  $\epsilon \approx 1 \text{ V/cm}$ . Thus  $\Delta p^2/2m^* = k \times 4 \times 10^{-3} \text{ }^\circ\text{K}$ . This value is very small compared with the other energies involved, and by the order of magnitude estimates of Sec. IV, the polarization resulting from such shifts is negligible. However, in samples about one order of magnitude purer than the ones investigated so far,  $\mu$  and  $\epsilon$  may be considerably larger and  $\Delta p^2/2m^*$  may be of order  $k\theta_i$ . The situation is different with regard to the mechanism suggested in Sec. III. It is very likely that, in the experiments of Clark and Feher,  $\theta_R^+$  was considerably different from  $\theta_R^-$ . The magnetic fields applied are such, that  $\omega_c \approx E_F$ , and, thus, the velocity of spin up and spin down electrons at the Fermi level is considerably different.

Not enough is known about the energy exchange between hot electrons and the lattice in InSb at helium temperatures. The scattering of electrons by ionized impurities is probably elastic and, therefore, contributes mostly to the momentum exchange, rather than the energy exchange; thus, the later may be due to interaction with acoustical or optical phonons.<sup>4</sup> However, whatever the mechanism responsible for the energy exchange is, it most likely depends strongly on the electronic velocity (for example, the matrix element for scattering of electrons by acoustical phonons is proportional to the electronic velocity<sup>13</sup>). The mean kinetic temperature is of the order  $20^\circ\text{--}50^\circ\text{K}$ , while the lattice temperature is  $4^\circ\text{K}$ . Consequently, it is likely that  $|\theta_R^+ - \theta_R^-|/|\theta_R^+ + \theta_R^-| \approx 1$ . Also, the elec-

<sup>10</sup> B. V. Paranjape and J. S. Levinger, Phys. Rev. **120**, 437 (1960).

<sup>11</sup> R. J. Sladek, J. Chem. Phys. Solids **8**, 515 (1959).

<sup>12</sup> R. Isaacson, Bull. Am. Phys. Soc. **7**, 484 (1962); *ibid.* **7**, 613 (1962).

<sup>13</sup> C. Kittel, *Introduction to Solid State Physics* (John Wiley & Sons, Inc., New York, 1900), 2nd ed., p. 303.

<sup>8</sup> J. Korringa, Physica **16**, 601 (1950).

<sup>9</sup> M. Gueron, Compt. Rend. **254**, 1969 (1962).

tronic spin-lattice relaxation may be due to the mechanisms suggested by Yafet,<sup>14</sup> in which the matrix element of the spin-reservoir interaction is strongly momentum-dependent. Thus, both necessary conditions for a sizable polarization via this mechanism are satisfied. A salient feature of this mechanism is, that when the magnetic field is changed so that the Fermi energy passes through a peak in the density of states (Fig. 5), the sign of the nuclear polarization should reverse, because the ratio of the velocities of spin up and spin down electrons at the Fermi surface reverses. This is apparently in agreement with experiment.

## VI. CONCLUSION

We have been considering idealized models that can account for a sizable nuclear polarization in a homogeneous semiconductor under the influence of homogeneous, constant electric and magnetic fields. We found that there are simple models characterized by the following parameters: The kinetic temperatures of spin up and spin down electrons,  $\theta_{R^+}$  and  $\theta_{R^-}$ ; the shift of the momentum distribution,  $\Delta p^2/2m^*$ ; the Zeeman energy  $\omega_e$ ; the Fermi energy  $E_F$ ; the cyclotron energy  $\omega_c$ ; and a dimensionless parameter  $\alpha$  describing the energy dependence of the matrix element responsible for electronic spin relaxation. We considered the following two classes of situations:  $\theta_{R^+} \neq \theta_{R^-}$ ,  $\Delta p^2 = 0$ , and  $\theta_{R^+} = \theta_{R^-}$ ,  $\Delta p^2 \neq 0$ . We saw that, in the first case, we may obtain nuclear polarizations of order  $\alpha|\theta_{R^+} - \theta_{R^-}|/|\theta_{R^+} + \theta_{R^-}|$ . We saw that in order to obtain a large difference between  $\theta_{R^+}$  and  $\theta_{R^-}$ ,  $\omega_e$  should not be small compared with  $E_F$ , and also  $\theta_{R^+} + \theta_{R^-}$  should not be large compared with  $E_F$ . However, if the magnetic field is so large that  $\omega_c \gg E_F$ , the rates for establishment of the nuclear polarization will be very slow. Thus, in effect, the optimum conditions for the establishment of nuclear polarization by this mechanism are  $\omega_e \approx E_F \approx \theta_{R^\pm} \gg \theta_{R^\mp}$ . In the second case, we saw that in order to obtain large nuclear polarizations, we should have  $\Delta p^2/2m^* \approx E_F$ ,  $\theta_R < \omega_e$ . In this case, polarizations of order  $\alpha \Delta p^2/2m^* E_F$  may be expected. In practice, it may prove very hard to shift the momentum distribution very much; therefore, it is probably hard to obtain sizable nuclear polarization by using this second scheme.

When the various parameters have the values resulting in optimum nuclear polarization, it is very hard to find rapidly converging expansions for the rate equations, and it may be necessary to resort to numerical integrations. Work is now under way in this laboratory in this direction.

## ACKNOWLEDGMENTS

The author wishes to acknowledge with gratitude many stimulating discussions with Dr. R. Traxler

and with Dr. R. Griffiths. The drawings were done by R. Winsett, and the manuscript was typed by Mrs. B. Jones. In particular, the author would like to acknowledge many stimulating conversations with Dr. W. G. Clark, and the continuous assistance of Dr. G. Feher in initiating this work and in providing innumerable ideas. The author is also indebted to Dr. A. Abragam for many suggestions and comments, to Dr. A. G. Redfield and Dr. C. P. Slichter for illuminating discussions about the concept of spin temperature, and to Dr. P. A. Wolff for pointing out the importance of electron-electron collisions.

## List of Symbols

$f^\pm(p)$	Momentum distribution function of $s_z = \pm \frac{1}{2}$ electrons.
$n^\pm$	Number of $s_z = \pm \frac{1}{2}$ electrons per unit volume.
$N^\pm$	Number of $I_z = \pm \frac{1}{2}$ nuclei per unit volume. (In this paper, only the $I = \frac{1}{2}$ case is treated.)
$p$	$\hbar k/\sqrt{2m^*}$ (so that the kinetic energy is $p^2$ ).
$\Delta p$	Displacement of the momentum distribution by an applied electric field.
$P_N$	Square of matrix element of electron-nuclear interaction.
$P_e$	Square of matrix element of electron-spin electron-translational motion interaction.
$w_N$	Transition probability for mutual electron-nucleus spin flips.
$w_e$	Transition probability for electron spin flips.
$\alpha$	Dimensionless parameter giving energy dependence of $P_e$ .
	$\alpha = \frac{1}{P_e(E)} \frac{dP_e(E)}{dE} \cdot E_F.$
$\gamma$	$(E_{F^+} - E_{F^-} + \hbar\omega_e)/\theta_R$ or $[\phi_F(\Delta p) - \phi_F(0) - \Delta p]/\phi_F$ . $E_F$ , $\phi_F$ are the energy and momentum at the Fermi surface.
$\theta_l$	Lattice temperature expressed in energy units.
$\theta_N$	Nuclear spin temperature expressed in energy units.
$\theta_R$	Reservoir (i.e., kinetic) temperature expressed in energy units.
$\theta_{R^\pm}$	Kinetic temperature of $s_z = \pm \frac{1}{2}$ electrons expressed in energy units.
$\theta_s$	Electron spin temperature expressed in energy units.
$\tau_N$	Nuclear longitudinal relaxation time ( $T_1$ ), assumed due to hyperfine interaction only.
$\tau_e$	Electron spin longitudinal relaxation time ( $T_1$ ).
$\omega_c$	Cyclotron frequency $e\hbar H/m^*c$ .
$\omega_e$	Electron Zeeman energy $g^*\beta H$ .
$\omega_N$	Nuclear Zeeman energy $g_N\beta_N H$ .

Some symbols that are used only in one place in this paper are not listed here.

<sup>14</sup> Y. Yafet, J. Phys. Chem. Solids **21**, 99 (1961), and in *Solid State Physics*, edited by F. Seitz and D. Turnbull (Academic Press Inc., New York, 1963).